

babyplast

The System



Vertical injection moulding machine



The smallest specialist
for **insert moulding**
no tie bars

vertical injection moulding machine Babyplast 6/10 VP
Compact size Maximum performance

Precision

The vertical Babyplast 6/10VP injection moulding machine, guarantees maximum precision, thanks to injection by piston and pre-plastification.
To obtain an optimum shot weight, 8 different piston diameters are available

Maximum performance for insert moulding

- Compact moulds that occupy minimum space
- User friendly
- Low power consumption
- Perfect for integration directly into an assembly line



Easy to consult and user friendly display

- Colour touch screen display
- User friendly
- Memory for over 100 mould settings
- Back-up on USB memory drive
- Record log of last 20 cycles
- Ethernet : modbus TCP connections



“V” table

- Mould with two lower (fixed) parts
- Ideal for inserts
- Small foot print

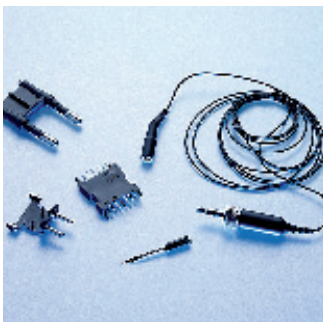



Babyplast 6/10VP vertical injection moulding machine

Standard features

- Quality control (cycle time/cushion/injection time.)
- Automatic shut down in case of alarms or out of tolerances.
- Decompression
- Two injection pressures
- 3 injection positions
- Tolerance band for temperatures
- PID temperature control
- Temperature in stand-by
- Speed control on all movements
- Mould safety
- 2 clamp speeds
- Central ejector with up to 9 shots
- Adjustable speed and pressure on ejection
- Ejector return sensor
- User friendly
- Multi lingual
- Memory for over 100 mould settings
- Part counter – Settings for production batches
- Integrated water manifold with 4 cooling zones
- Back-up on USB memory drive
- Intrusion programme
- Hour meter
- Sprue break
- Transducer on clamp and injection piston
- Pressure control using electronic pressure transducer
- Motor controlled by inverter
- Colour touch screen display
- 4th zone for mould temperature control
- Double start buttons.

Optional features

- Mixer nozzle (static mixer)
- Euromap 67
- Accumulator for injection speed
- Shut off nozzle
- Nozzle with tip for injecting directly into part.
- 5th heater zone for mould temperature control
- Hydraulic or pneumatic core pull
- Ethernet modbus
- LSR injection unit
- Rotating table
- Air blow
- Special spec. For high temperature materials
- Hot runners
- Output for wiper arm to reject parts

Accessories

- Chiller
- Drier
- Loader for plastic materials (electric or Venturi)
- Temperature controller for moulds
- Electrical cabinet for accessories

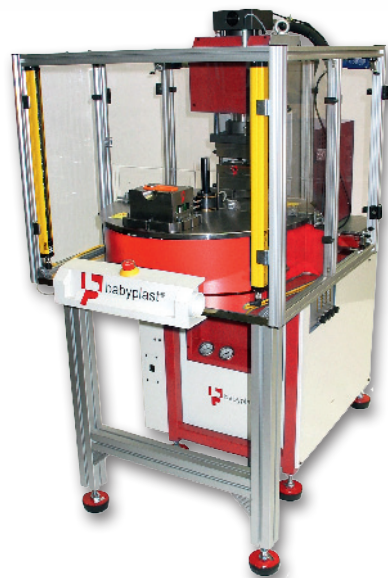

Rotating table

- Perfect for integration directly into an assembly line
- 2 station table – diam. 600mm
- 180° rotation in 2 secs.
- Light barriers



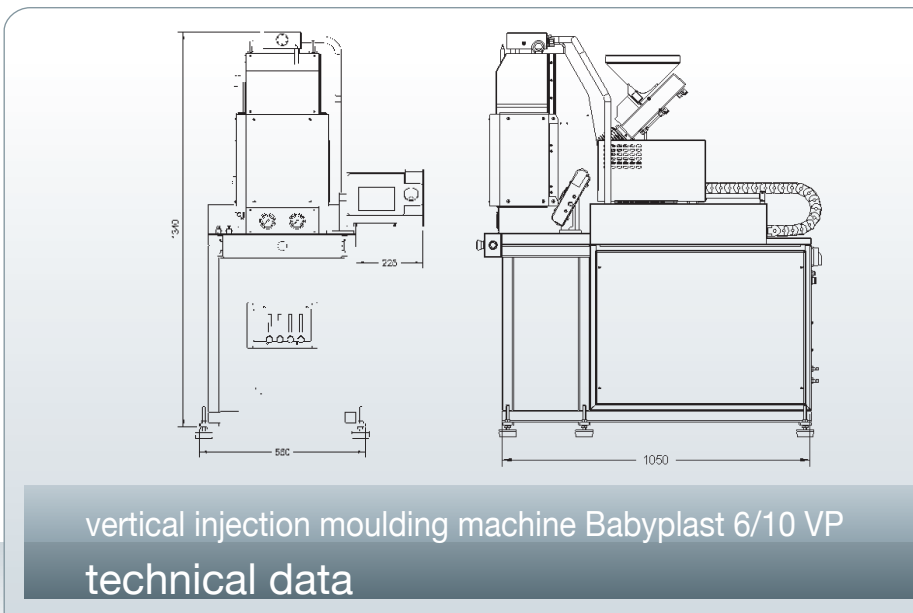

vertical injection moulding machine Babyplast 6/10 VP
technical data

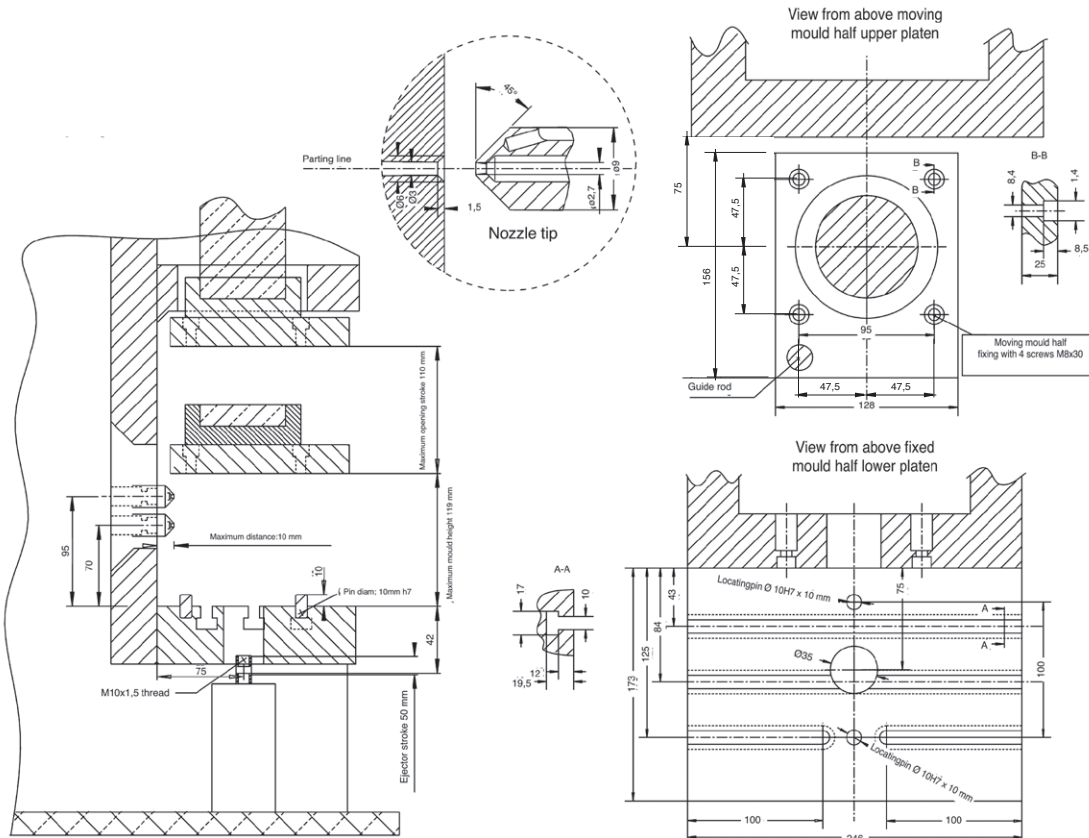

We reserve the right to make modifications. Date of issue 15/10/2010

Standard						Standard Plus						Opening stroke mm:	110 mm	Oil tank capacity:	16 l
Piston diameter (mm):	10	12	14	16	18	16	18	20	22	24	Ejector force:	7,5 KN	Power consumption:	3 KW	
Volume (cm3):	4	6,5	9	12	15	16	20	25	30	36	Ejector stroke:	50 mm	Weight:	350 Kg	
Injection pressure (Kg/cm3):	2030	1850	1340	1030	815	1535	1250	980	830	680	Fixed platen WxL:	246x173 mm	Power supply:	3ph -230/400V-50/60Hz	
clamping force (KN):	62,5 kN										Mobile platen WxL:	128x155 mm	Noise level:	<70dBA	
Minimum mould height:	119 mm														
Maximum distance between platens:	229 mm														